

ARTISTE MONET™



ELATION® PROFESSIONAL



The **Artiste Monet™** is an extremely bright fully featured LEDProfile fixture offering outstanding projection quality and a wide color mixing gamut through its variable SpectraColor engine.

Providing up to 45,000 lumens from its efficient 950W 6,500K LED engine the Monet is the ideal fixture for any application requiring superior output, bright and powerful beams, quiet operation as well as stunningly precise gobos and colors. Monet integrates Elation's new SpectraColor system which offers traditional CMY mixing but adds a variable RGB color mix for rich saturated primaries. In combination with the variable CTO the Monet allows for colors that were previously impossible to achieve, from theatrical pastels to the most vibrant red or blues ever produced by a color mixing system. The wide color gamut of the Artiste Monet achieved by seven color mixing flags with 16bit precision provides artistic possibilities that are truly inspiring. The fixed color wheel offers UV and High CRI options to round out the amazing color range of the fixture.

The full blackout framing array includes Elation's newly designed unlimited indexing and continuous rotation control. Shapes can rotate like gobos while morphing and transforming, allowing new creative transitions and interesting projection and aerial effects not previously possible. Monet also offers a comprehensive FX package with 7 rotating and 7 fixed interchangeable glass gobos, full animation wheel, dual prisms, dual frost and a high-speed Iris. With a fast zoom range from 6.8° to 55° and an impressive 160mm front lens the Monet has the power to cut through at even great distances in arena touring environments or large TV or Theater Stages. DMX controllable variable fan modes offer low noise operation for noise sensitive environments.

The fixture ships in a cardboard box with a custom fitted polyurethane foam FIL (Foam In Lay) insert. This foam insert easily fits into a custom sized flight case (not included), and provides enhanced impact protection during transport.

FEATURES

High Efficiency 950W 6,500K White LED Engine

Up to 45,000 Total Lumen Fixture Output

SpectraColor CMYRGB Array and Variable Linear CTO

6 Position Color Wheel, High CRI, UV Filter

Complete FX System Featuring Rotating and Fixed Gobos, Animation, Iris, Dual Prism, Dual Frost

Full Blackout Framing System with 360° Continuous Index and Rotation of Shapes

6.8° to 55° Wide Zoom / Large 160mm Front Aperture

DMX Controllable Variable Fan Modes / Low Noise Operation

FIL (Form In Lay) Polyurethane Foam Packaging Included



Specifications subject to change without notice ©Elation Professional 12/16/19

Elation Professional USA | 6122 S. Eastern Ave. | Los Angeles, CA. 90040
323-582-3322 | 323-832-9142 fax | www.elationlighting.com | info@elationlighting.com

Elation Professional B.V. | Junostraat 2 | 6468 EW Kerkrade, The Netherlands
+31 45 546 85 66 | +31 45 546 85 96 fax | www.elationlighting.eu | info@elationlighting.eu

PRODUCT SPECIFICATIONS

SOURCE

950W 6,500K Bright White LED Engine
30,000 Hour Average LED Life*

*Test lab conditions. May vary depending on several factors including but not limited to: Environmental Conditions, Power/Voltage, Usage Patterns (On-Off Cycling), Control, Dimming, and Lamp Mode.

PHOTOMETRIC DATA

45,000 Total Lumen Output
CRI 72+ (84 with HCRI Filter)

EFFECTS

6.8° - 55° Motorized Zoom (large 160mm front lens)
4 Rotating Full Blackout Framing Blades
360° Continuous Framing Index and Rotation
Full 360° Bi-Directional Animation Wheel
4-Facet and Linear Rotating Prisms
2 Variable Frost Filters (Light and Wash)
Internal Color, Framing, Prism, and Frost Macros
Motorized Iris with Variable Pulse Effects
Variable 16-bit Dimming Curve Modes
High Speed Electronic Shutter and Strobe
DMX Controllable LED Refresh Rate

COLOR

SpectraColor CMY + RGB Color Mixing Array
6 Dichroic Colors including High CRI Filter and UV
Linear CTO Color Correction

GOBOS

2 Gobo Wheels
7 Rotating / Indexing Interchangeable Glass Gobos
7 Static Glass Interchangeable Gobos

CONTROL / CONNECTIONS

2 DMX Channel Modes (40 / 67)
16-bit Pan, Tilt and Dimming Control
Motorized Focus and Auto-Focus Presets
DMX Controllable Variable Fan Modes
DMX, RDM, Art-NET, sACN Protocol Support
(6) Button Touch Control Panel
Full Color 180° Reversible LCD Menu Display
Hibernation Mode (Power Save)
Locking 5pin XLR DMX, RJ45 Ethernet, and Power
USB Connection (Firmware Updates)

SIZE / WEIGHT*

Length: 18.55" (471.09mm)
Width: 22.97" (583.37mm)
Height: 31.51" (800.40mm)
Weight: 94.0 lbs (42.6 kg)

*Subject of change without notice.

ELECTRICAL / THERMAL

AC 100-240V - 50/60Hz
1,350 Max Power Consumption
14°F to 113°F (-10°C to 45°C)

APPROVALS / RATINGS

CE | cETLus | IP20

COLORS - GOBOS - ANIMATION

COLOR FLAGS



COLOR WHEEL



INTERCHANGEABLE-ROTATING GLASS GOBO WHEEL 1



STATIC-FIXED GLASS GOBO WHEEL 2



ANIMATION WHEEL

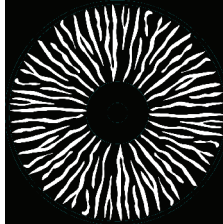

DIMENSIONAL DRAWINGS

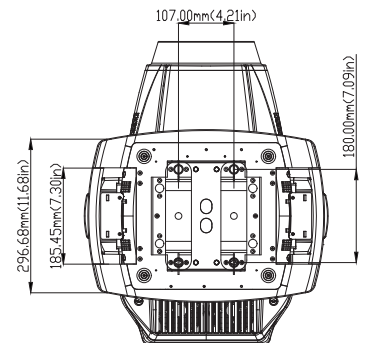
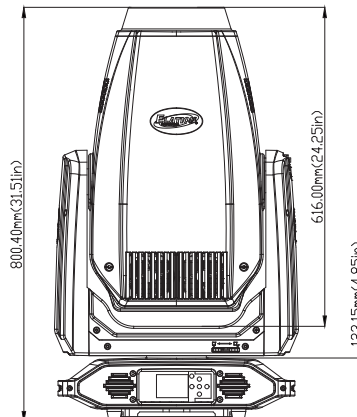
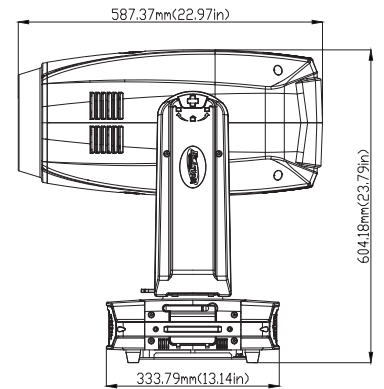
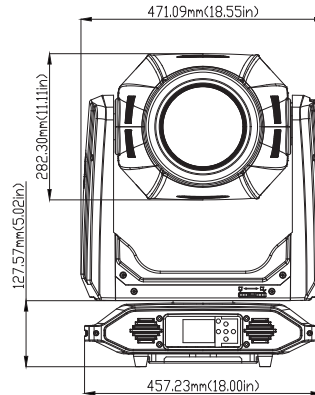

*DRAWINGS NOT TO SCALE

ORDERING INFORMATION

EAM990	Artiste Monet
DRCPRO001	Dual Pro Road Case Artiste Monet/Proteus Maximus

Specifications subject to change without notice ©Elation Professional 12/16/19



Elation Professional USA | 6122 S. Eastern Ave. | Los Angeles, CA. 90040
323-582-3322 | 323-832-9142 fax | www.elationlighting.com | info@elationlighting.com

Elation Professional B.V. | Junostraat 2 | 6468 EW Kerkrade, The Netherlands
+31 45 546 85 66 | +31 45 546 85 96 fax | www.elationlighting.eu | info@elationlighting.com